



Lecture 13:

Memory Consistency

Parallel Computer Architecture and Programming
CMU 15-418/15-618, Fall 2016

What is Correct Behavior for a Parallel Memory Hierarchy?

- Note: **side-effects of writes** are only **observable** when *reads* occur
 - so we will focus on the **values returned by reads**
- Intuitive answer:
 - **reading a location** should return the **latest value written** (by any thread)
- Hmm... **what does “latest” mean exactly?**
 - within a thread, it can be defined by program order
 - but what about **across threads?**
 - the most recent write in **physical time?**
 - hopefully not, because there is no way that the hardware can pull that off
 - » e.g., if it takes >10 cycles to communicate between processors, there is no way that processor 0 can know what processor 1 did 2 clock ticks ago
 - most recent based upon **something else?**
 - Hmm...

Refining Our Intuition

Thread 0

```
// write evens to X
for (i=0; i<N; i+=2) {
    X = i;
    ...
}
```

Thread 1

```
// write odds to X
for (j=1; j<N; j+=2) {
    X = j;
    ...
}
```

Thread 2

```
...
A = X;
...
B = X;
...
C = X;
...
```

(Assume: X=0 initially, and these are the only writes to X.)

- What would be some clearly **illegal combinations** of (A,B,C)?
- How about:
 - (4,8,1)?
 - (9,12,3)?
 - (7,19,31)?
- What can we generalize from this?
 - writes from any **particular thread** must be **consistent with program order**
 - in this example, observed even numbers must be increasing (ditto for odds)
 - **across threads**: writes must be consistent with **a valid interleaving of threads**
 - not physical time! (programmer cannot rely upon that)

Visualizing Our Intuition

Thread 0

```
// write evens to X
for (i=0; i<N; i+=2) {
    X = i;
    ...
}
```

Thread 1

```
// write odds to X
for (j=1; j<N; j+=2) {
    X = j;
    ...
}
```

Thread 2

```
...
A = X;
...
B = X;
...
C = X;
```

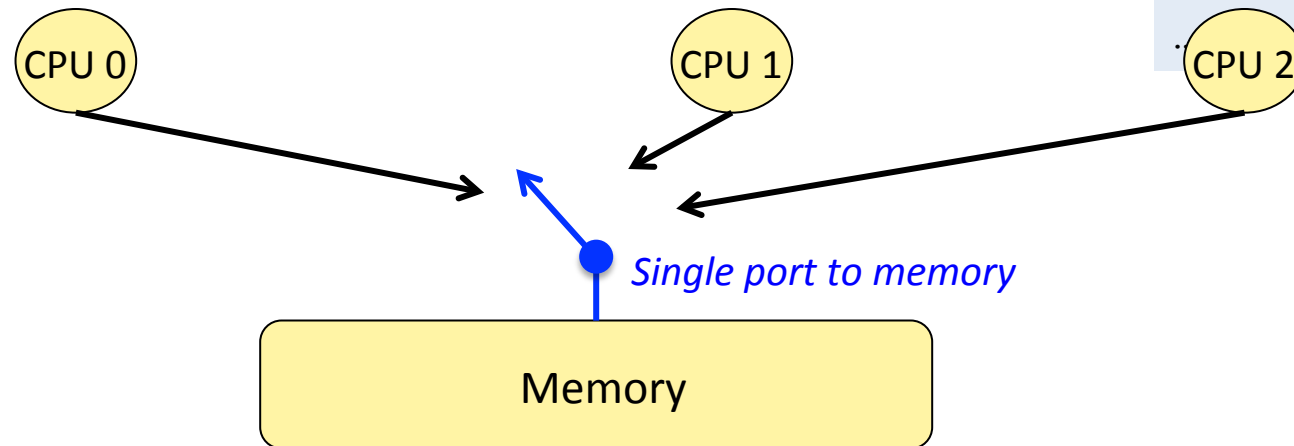

- Each thread proceeds in **program order**
- **Memory accesses interleaved** (one at a time) to a **single-ported memory**
 - rate of progress of each thread is **unpredictable**

Correctness Revisited

Thread 0

```
// write evens to X
for (i=0; i<N; i+=2) {
    X = i;
    ...
}
```

Thread 1

```
// write odds to X
for (j=1; j<N; j+=2) {
    X = j;
    ...
}
```

Thread 2

```
...
A = X;
...
B = X;
...
C = X;
```

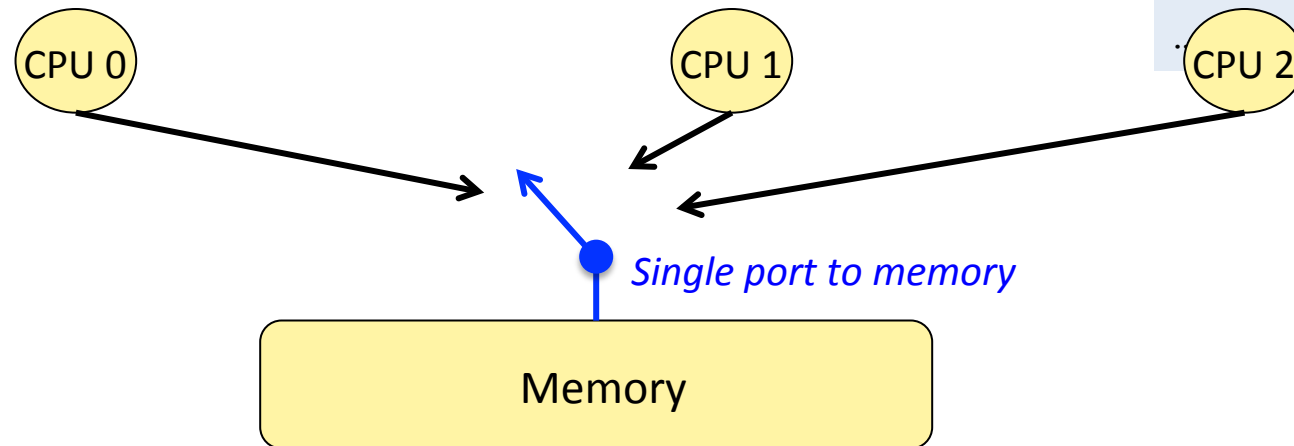

Recall: “reading a location should return the **latest value written** (by any thread)”

- “**latest**” means consistent with **some interleaving that matches this model**
- this is a **hypothetical interleaving**; the machine didn’t necessary do this!

Part 2 of Memory Correctness: Memory Consistency Model

1. “Cache Coherence”

- do all loads and stores to a **given cache block** behave correctly?

2. “Memory Consistency Model” (sometimes called “Memory Ordering”)

- do all loads and stores, even to **separate cache blocks**, behave correctly?

Recall: our **intuition**

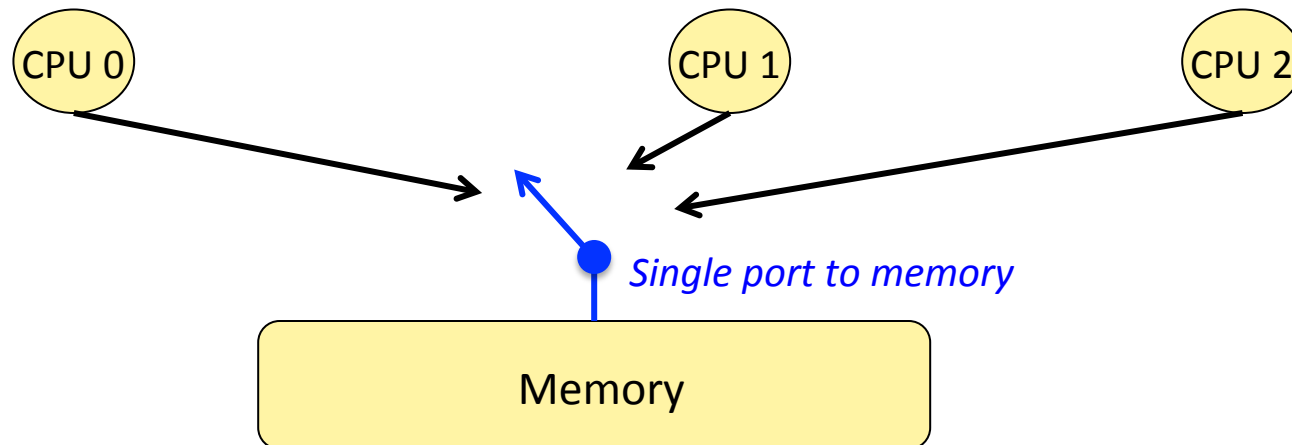

Why is this so complicated?

- Fundamental issue:
 - loads and stores are very expensive, even on a uniprocessor
 - can easily take 10's to 100's of cycles
- What programmers intuitively expect:
 - processor atomically performs one instruction at a time, in program order
- In reality:
 - if the processor actually operated this way, it would be painfully slow
 - instead, the processor aggressively reorders instructions to hide memory latency
- Upshot:
 - within a given thread, the processor preserves the program order illusion
 - but this illusion has nothing to do with what happens in physical time!
 - from the perspective of other threads, all bets are off!

Hiding Memory Latency is Important for Performance

- Idea: *overlap* memory accesses with other accesses and computation

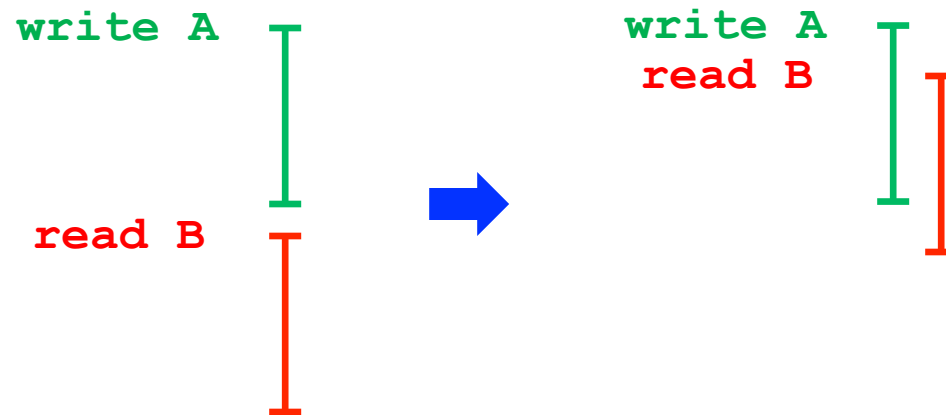

- Hiding **write** latency is simple in uniprocessors:
 - add a **write buffer**
- (But this affects **correctness** in multiprocessors)

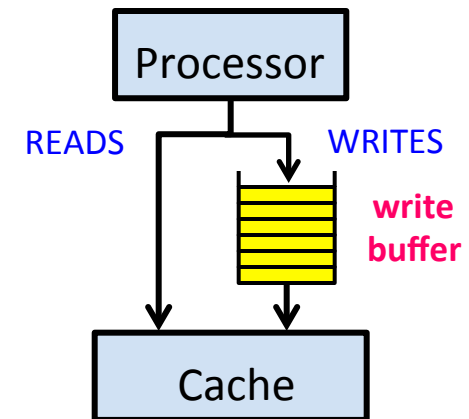

How Can We Hide the Latency of Memory Reads?

“Out of order” pipelining:

- when an instruction is stuck, perhaps there are subsequent instructions that can be executed

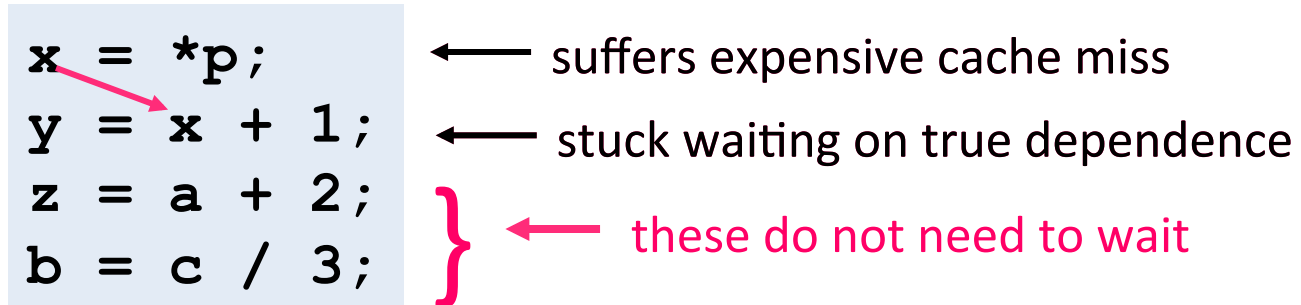

- Implication: memory accesses may be performed out-of-order!!!

What About Conditional Branches?

- Do we need to wait for a conditional branch to be resolved before proceeding?
 - No! Just **predict the branch outcome and continue executing speculatively**.
 - if prediction is wrong, squash any side-effects and restart down correct path

```
x = *p;  
y = x + 1;  
z = a + 2;  
b = c / 3;  
if (x != z)  
    d = e - 7;  
else d = e + 5;  
...
```

if hardware guesses that this is true
then execute “then” part (speculatively)
(without waiting for **x** or **z**)

How Out-of-Order Pipelining Works in Modern Processors

- Fetch and graduate instructions in-order, but **issue out-of-order**

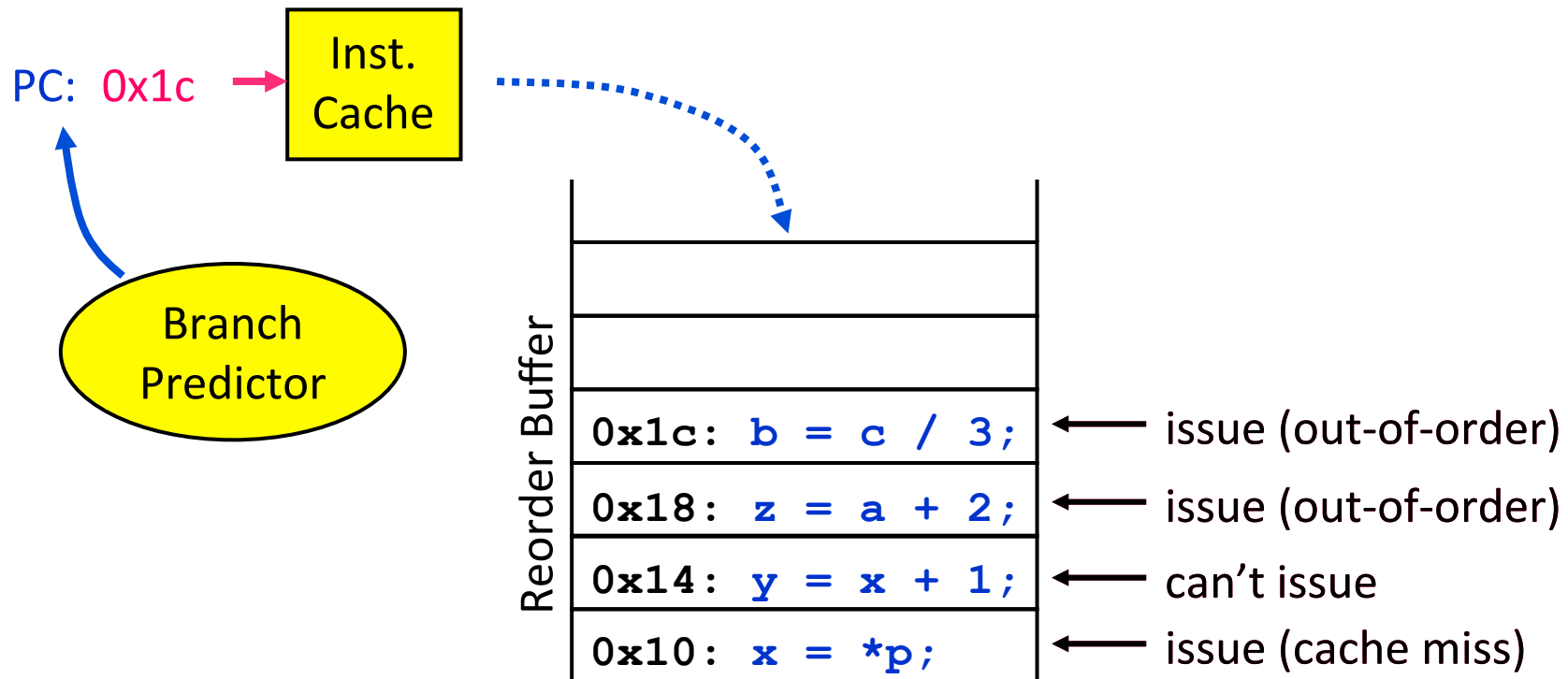

- Intra-thread dependences are preserved, but **memory accesses get reordered!**

Analogy: Gas Particles in Balloons

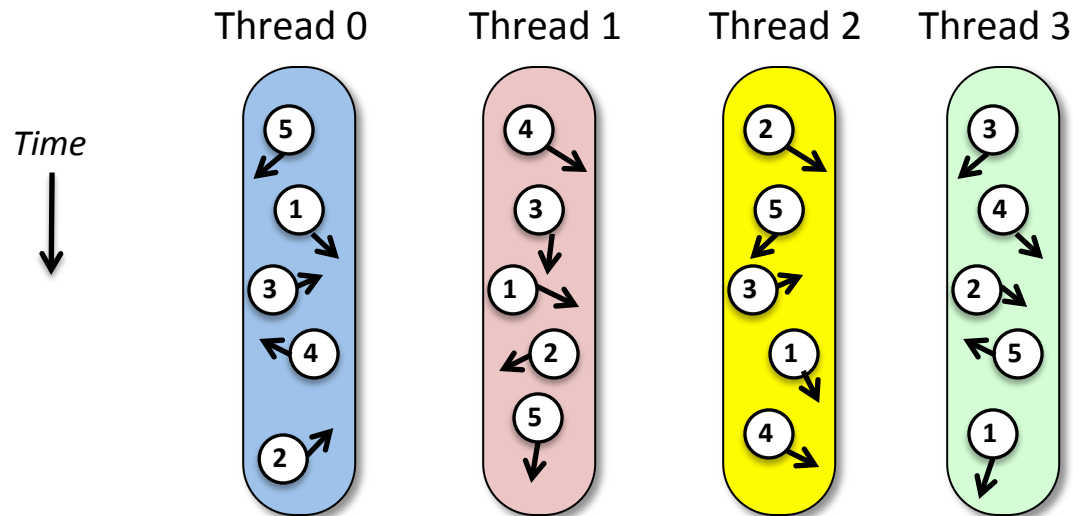

- Imagine that each instruction within a thread is a gas particle inside a twisty balloon
- They were numbered originally, but then they start to move and bounce around
- **When a given thread observes memory accesses from a *different* thread:**
 - those memory accesses can be (almost) **arbitrarily jumbled around**
 - like trying to locate the position of a particular gas particle in a balloon
- As we'll see later, the only thing that we can do is to put *twists* in the balloon

Uniprocessor Memory Model

- **Memory model** specifies **ordering constraints** among accesses
- **Uniprocessor model**: memory accesses **atomic** and **in program order**

write A
write B
read A
read B

*Reads check for
matching addresses
in write buffer*

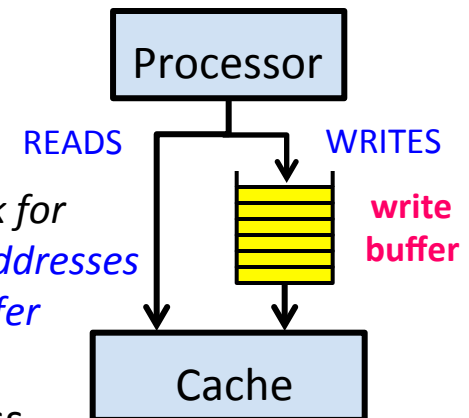

- Not necessary to maintain sequential order for correctness
 - **hardware**: buffering, pipelining
 - **compiler**: register allocation, code motion
- **Simple** for programmers
- Allows for **high performance**

In Parallel Machines (with a Shared Address Space)

- Order between **accesses to different locations** becomes important

(Initially A and Ready = 0)

P1

A = 1;

Ready = 1;

P2

while (**Ready** != 1);

... = **A**;

How Unsafe Reordering Can Happen

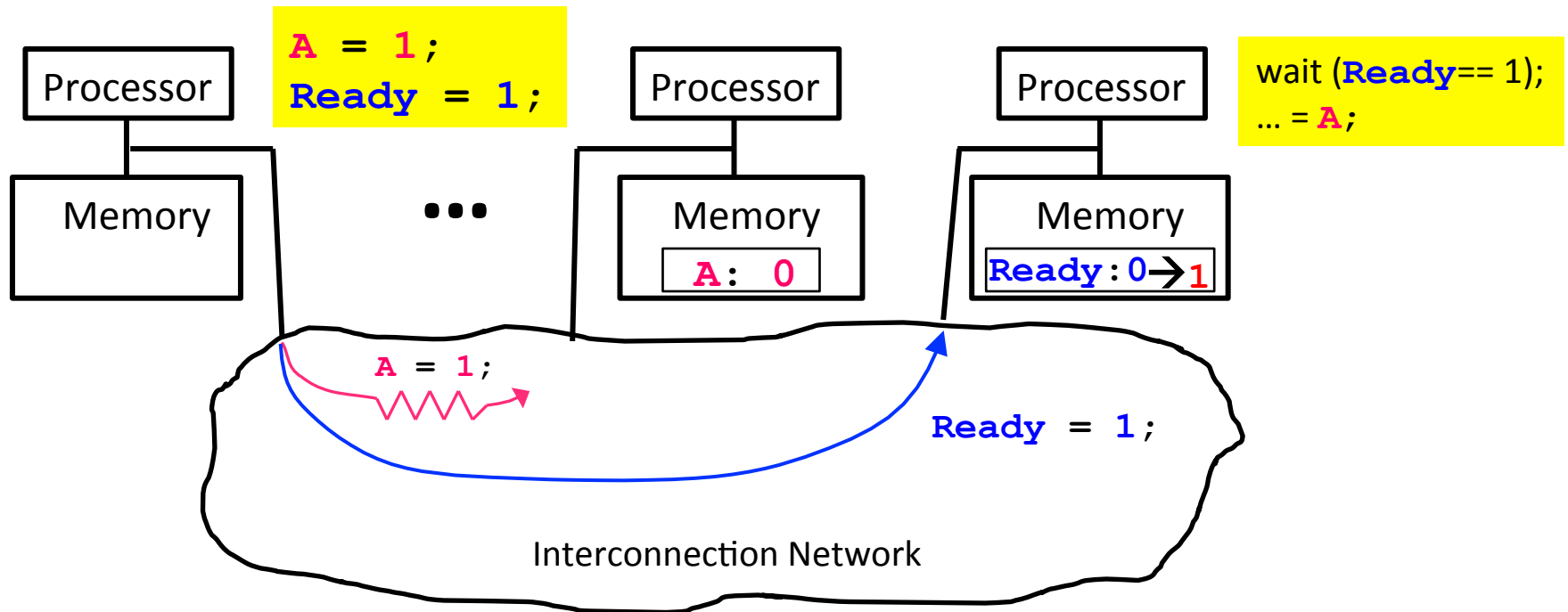

- Distribution of memory resources
 - accesses issued in order may be observed out of order

Caches Complicate Things More

- Multiple copies of the same location

`A = 1;`



`wait (A == 1);`
`B = 1;`



`wait (B == 1);`
`... = A;`

Oops!

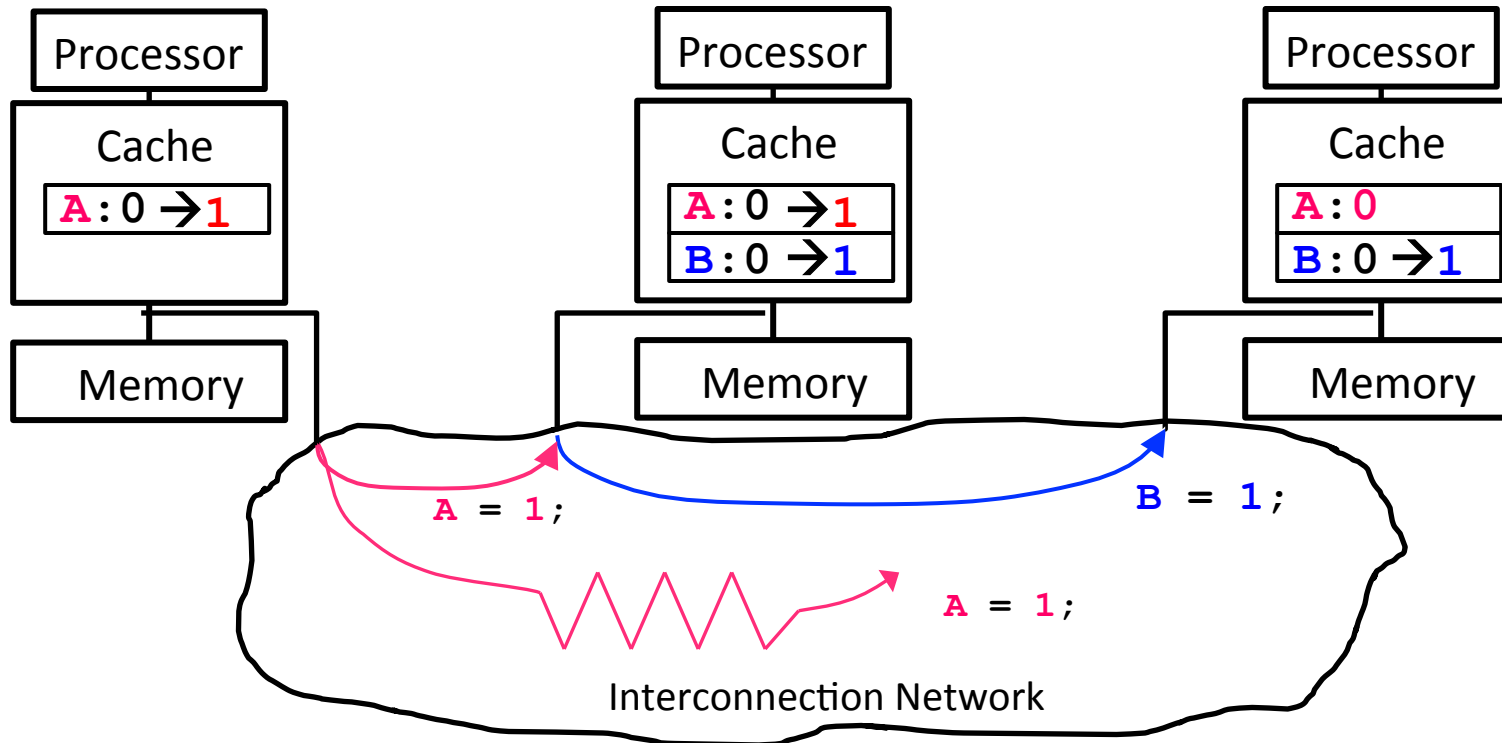

Our Intuitive Model: “Sequential Consistency” (SC)

- Formalized by Lamport (1979)
 - accesses of each processor in **program order**
 - all accesses appear in **sequential order**

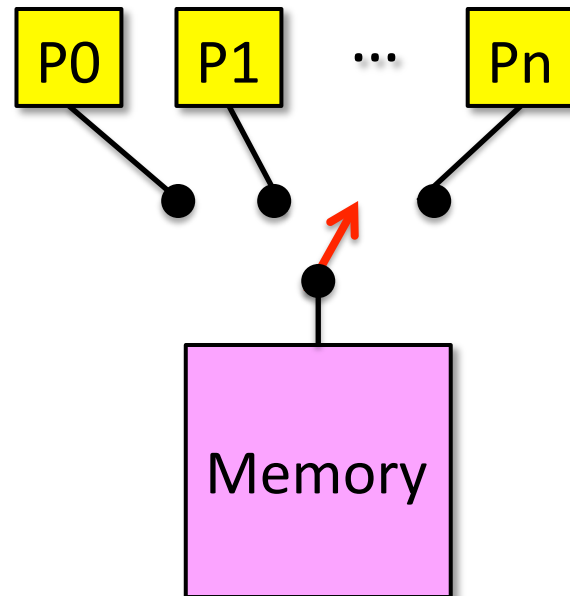

- Any order implicitly assumed by programmer is maintained

Example with Sequential Consistency

Simple Synchronization:

P0

A = 1 (a)

Ready = 1 (b)

P1

x = **Ready** (c)

y = **A** (d)

- all locations are initialized to 0
- possible outcomes for (x,y):
 - (0,0), (0,1), (1,1)
- (x,y) = (1,0) is **not a possible outcome** (i.e. **Ready** = 1, **A** = 0):
 - we know a->b and c->d by program order
 - b->c implies that a->d
 - y==0 implies d->a which leads to a contradiction
 - *but real hardware will do this!*

Another Example with Sequential Consistency

Stripped-down version of a 2-process mutex (minus the turn-taking):

P0

want[0] = 1 (a)

x = want[1] (b)

P1

want[1] = 1 (c)

y = want[0] (d)

- all locations are initialized to 0
- possible outcomes for (x,y):
 - (0,1), (1,0), (1,1)
- (x,y) = (0,0) is **not a possible outcome** (i.e. **want[0] = 0, want[1] = 0**):
 - a->b and c->d implied by program order
 - x = 0 implies b->c which implies a->d
 - a->d says y = 1 which leads to a contradiction
 - similarly, y = 0 implies x = 1 which is also a contradiction
 - *but real hardware will do this!*

One Approach to Implementing Sequential Consistency

1. Implement **cache coherence**
 - writes to the **same location** are observed in same order by all processors
 2. For each processor, **delay start of memory access until previous one completes**
 - each processor has only one outstanding memory access at a time
- What does it mean for a memory access to **complete**?

When Do Memory Accesses Complete?

- Memory Reads:

- a read completes **when its return value is bound**

```
load r1 ← x
```

x = ???



*(Find **x** in memory system)*

x = 17



r1 = 17

When Do Memory Accesses Complete?

- Memory Reads:
 - a read completes **when its return value is bound**
- Memory Writes:
 - a write completes **when the new value is “visible” to other processors**

`store 23 → x`

`x = 23`



*(Commit to memory order)
(aka “serialize”)*

- What does “visible” mean?
 - it does NOT mean that other processors have necessarily seen the value yet
 - it means the **new value is committed to the hypothetical serializable order (HSO)**
 - a later read of `x` in the HSO will see either this value or a later one
 - (for simplicity, assume that writes occur atomically)

Summary for Sequential Consistency

- Maintain order between shared accesses in each processor

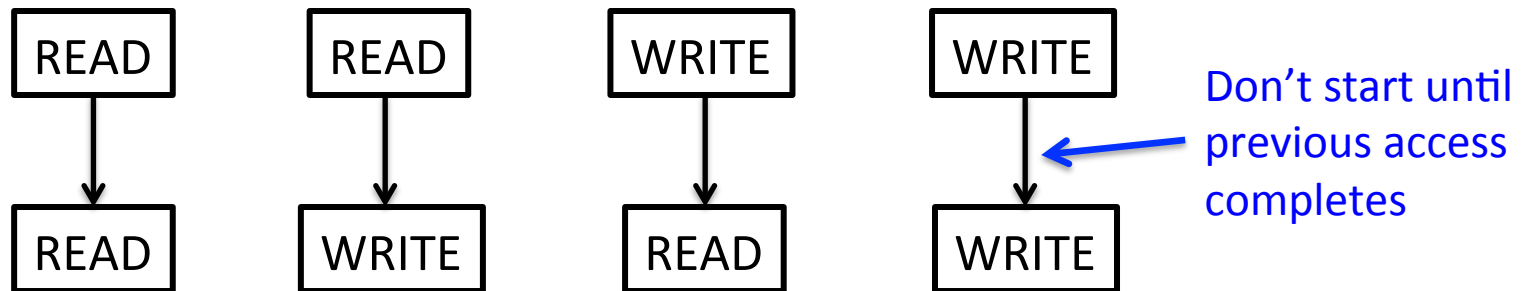

- Balloon analogy:
 - like putting a twist between each individual (ordered) gas particle

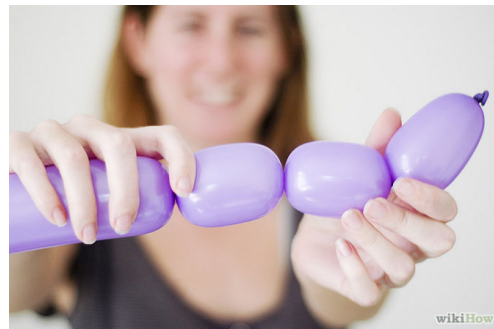

- Severely restricts common hardware and compiler optimizations

Performance of Sequential Consistency

- Processor issues accesses **one-at-a-time** and **stalls for completion**

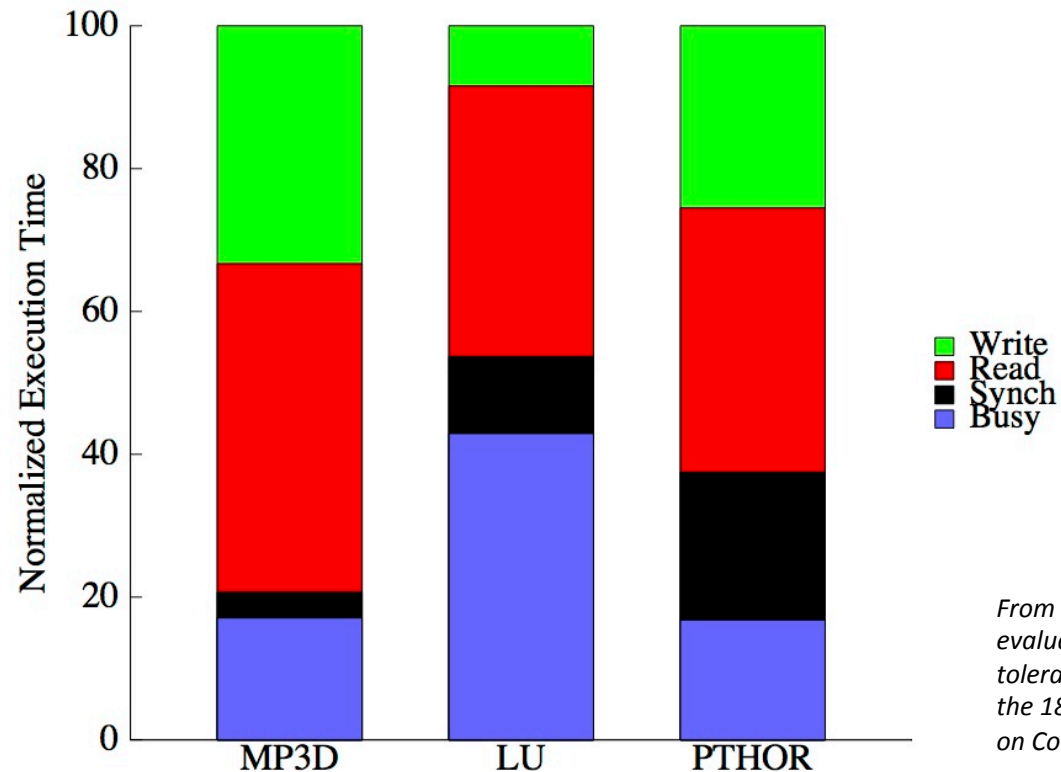

From Gupta et al, "Comparative evaluation of latency reducing and tolerating techniques." In Proceedings of the 18th annual International Symposium on Computer Architecture (ISCA '91)

- Low processor utilization (17% - 42%) even with caching**

Alternatives to Sequential Consistency

- Relax constraints on memory order

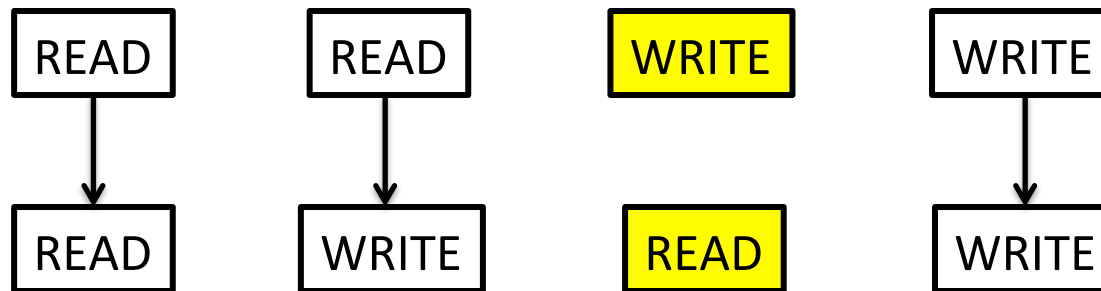

Total Store Ordering (TSO) (Similar to Intel)

See Section 8.2 of “Intel® 64 and IA-32 Architectures Software Developer’s Manual, Volume 3A: System Programming Guide, Part 1”, <http://www.intel.com/content/dam/www/public/us/en/documents/manuals/64-ia-32-architectures-software-developer-vol-3a-part-1-manual.pdf>

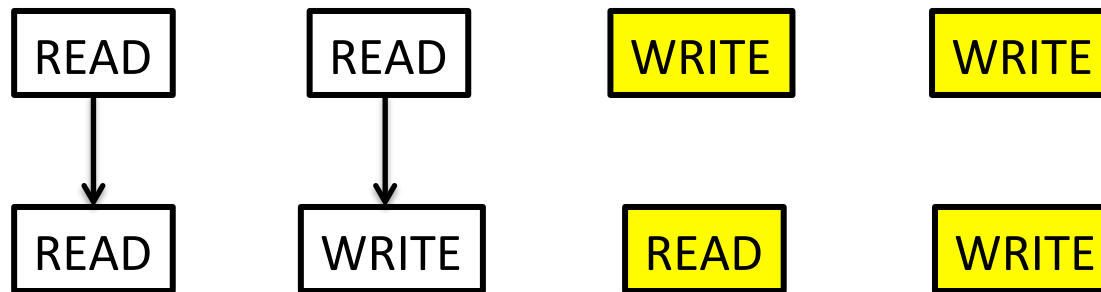

Partial Store Ordering (PSO)

Performance Impact of TSO vs. SC

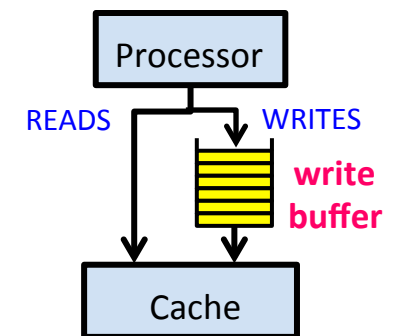
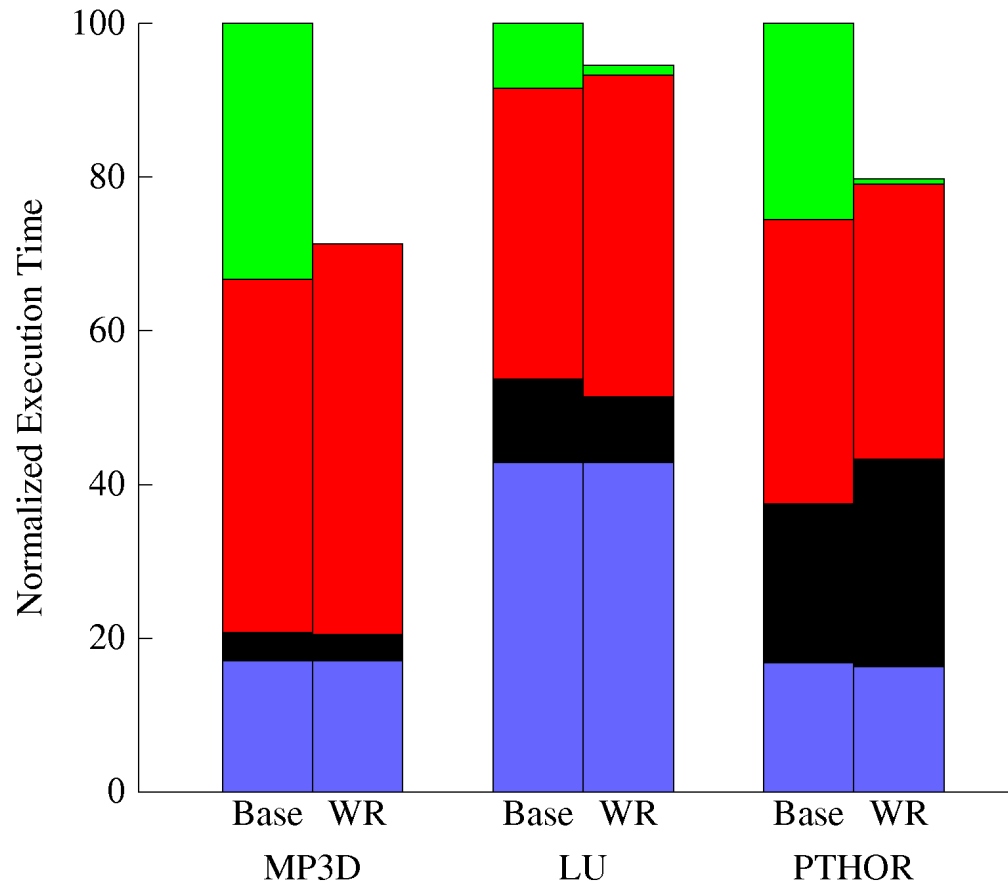

- Can use a **write buffer**
- Write latency is effectively hidden

But Can Programs Live with Weaker Memory Orders?

- “Correctness”: same results as sequential consistency
- Most programs don’t require strict ordering (all of the time) for “correctness”

Program Order

```
A = 1;  
  ↓  
B = 1;  
  ↓  
unlock L;    lock L;  
              ↓  
              ... = A;  
              ↓  
              ... = B;
```

Sufficient Order

```
A = 1;  
  ↓  
B = 1;  
  ↓  
unlock L;    lock L;  
              ↓  
              ... = A;  
              ↓  
              ... = B;
```

- But how do we know when a program will behave correctly?

Identifying Data Races and Synchronization

- Two accesses *conflict* if:
 - (i) access **same location**, and (ii) at least one is a **write**
- Order accesses by:
 - **program order (po)**
 - **dependence order (do)**: op1 --> op2 if op2 reads op1

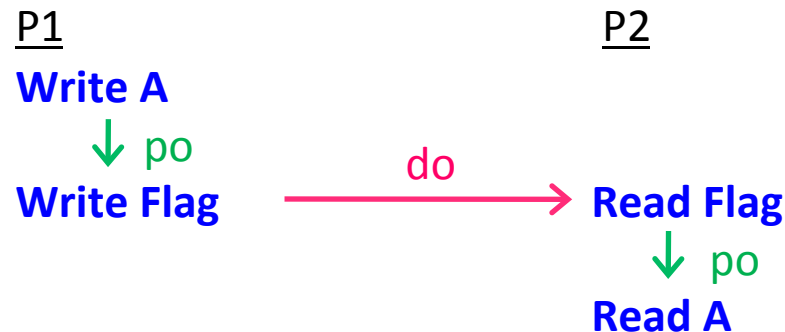

- Data Race:
 - two conflicting accesses on different processors
 - not ordered by intervening accesses
- Properly Synchronized Programs:
 - all synchronizations are explicitly identified
 - all data accesses are ordered through synchronization

Optimizations for Synchronized Programs

- Intuition: many parallel programs have mixtures of “private” and “public” parts*
 - the “private” parts must be **protected by synchronization** (e.g., locks)
 - can we **take advantage of synchronization to improve performance?**

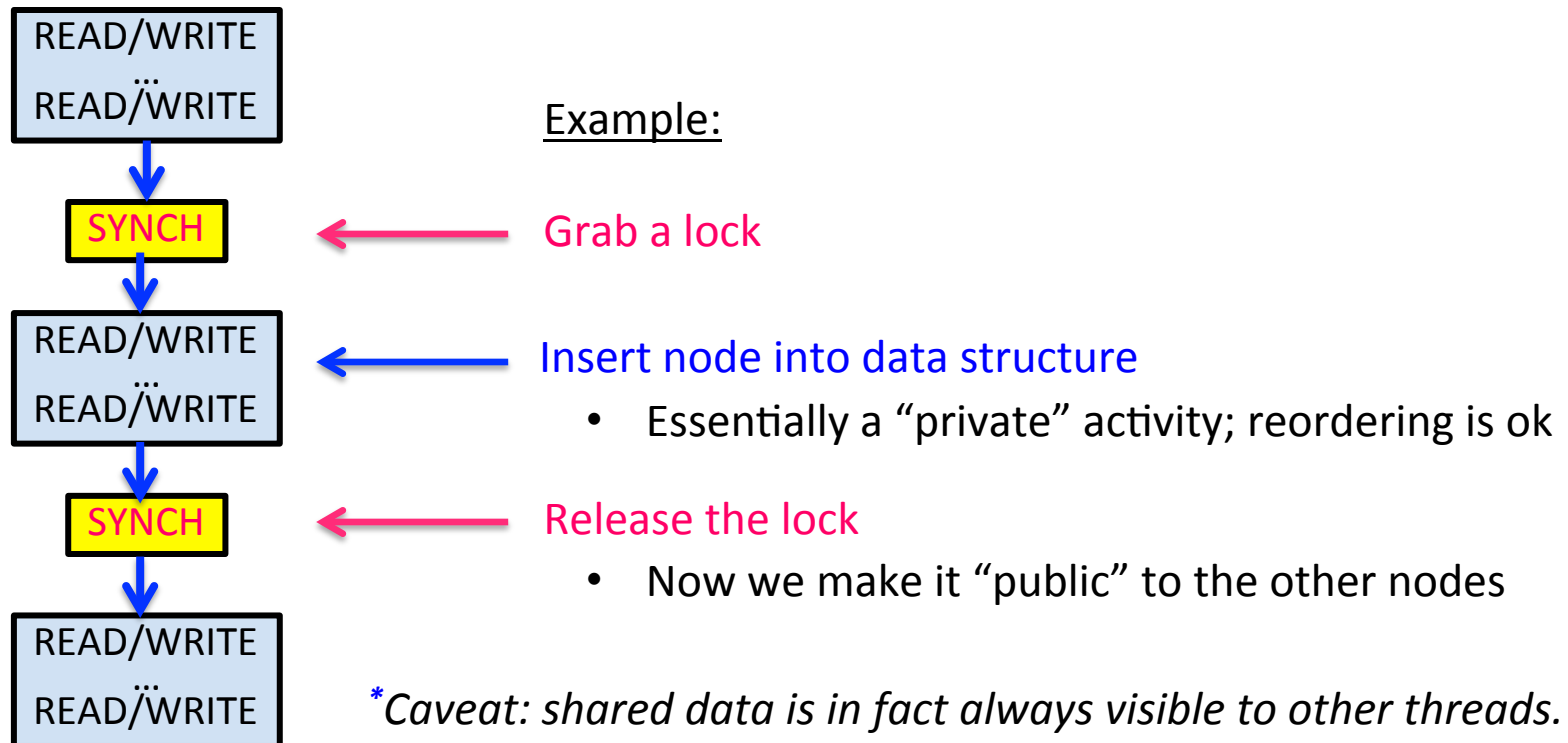

Optimizations for Synchronized Programs

- Exploit information about synchronization

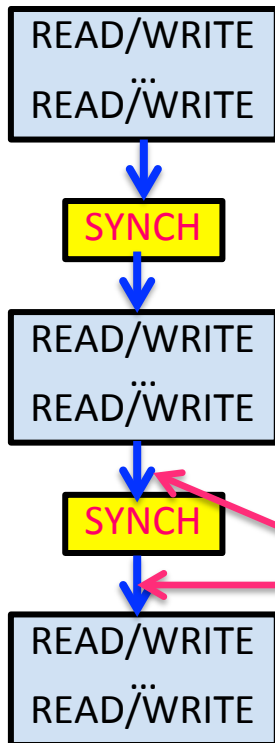

Between synchronization operations:

- we can **allow reordering** of memory operations
- *(as long as intra-thread dependences are preserved)*

Just before and just after synchronization operations:

- **thread must wait for all prior operations to complete**

“Weak Ordering” (WO)

- properly synchronized programs should yield the **same result as on an SC machine**

Intel's MFENCE (Memory Fence) Operation

- An **MFENCE** operation enforces the ordering seen on the previous slide:
 - does not begin until all prior reads & writes from that thread have completed
 - no subsequent read or write from that thread can start until after it finishes

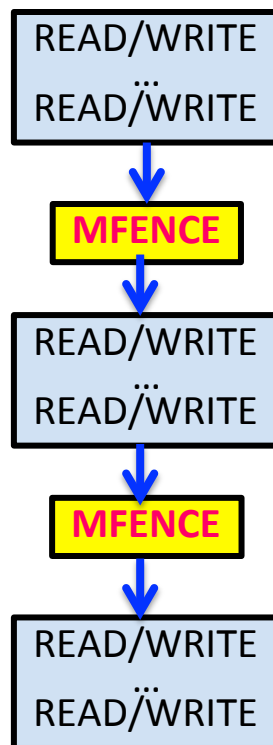

Balloon analogy: it is a twist in the balloon

- no gas particles can pass through it



(wikiHow)

Good news: **xchg** does this implicitly!

ARM Processors

- ARM processors have a **very relaxed consistency model**
- ARM has some great examples in their programmer's reference:
 - http://infocenter.arm.com/help/topic/com.arm.doc.genc007826/Barrier_Litmus_Tests_and_Cookbook_A08.pdf
- A great list regarding relaxed memory consistency in general:
 - <http://www.cl.cam.ac.uk/~pes20/weakmemory/>

Common Misconception about MFENCE

- MFENCE operations **do NOT** push values out to other threads
 - it is not a magic “make every thread up-to-date” operation
- Instead, they simply **stall the thread that performs the MFENCE**

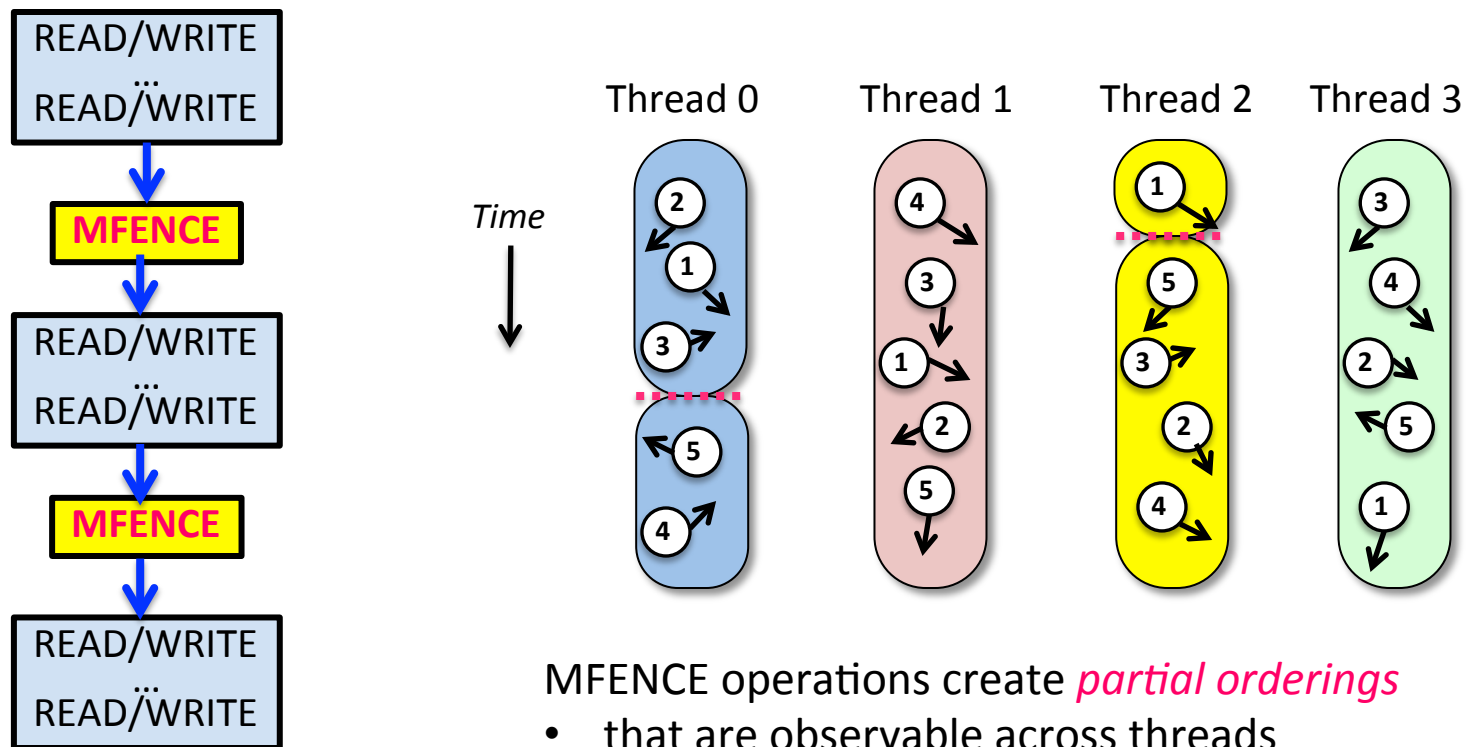

Earlier (Broken) Example Revisited

Where exactly should we insert MFENCE operations to fix this?

P0

[1: Here?]

A = 1

[2: Here?]

Ready = 1

[3: Here?]

P1

[4: Here?]

x = Ready

[5: Here?]

y = A

[6: Here?]

Exploiting Asymmetry in Synchronization: “Release Consistency”

- Lock operation: only gains (“acquires”) permission to access data
- Unlock operation: only gives away (“releases”) permission to access data

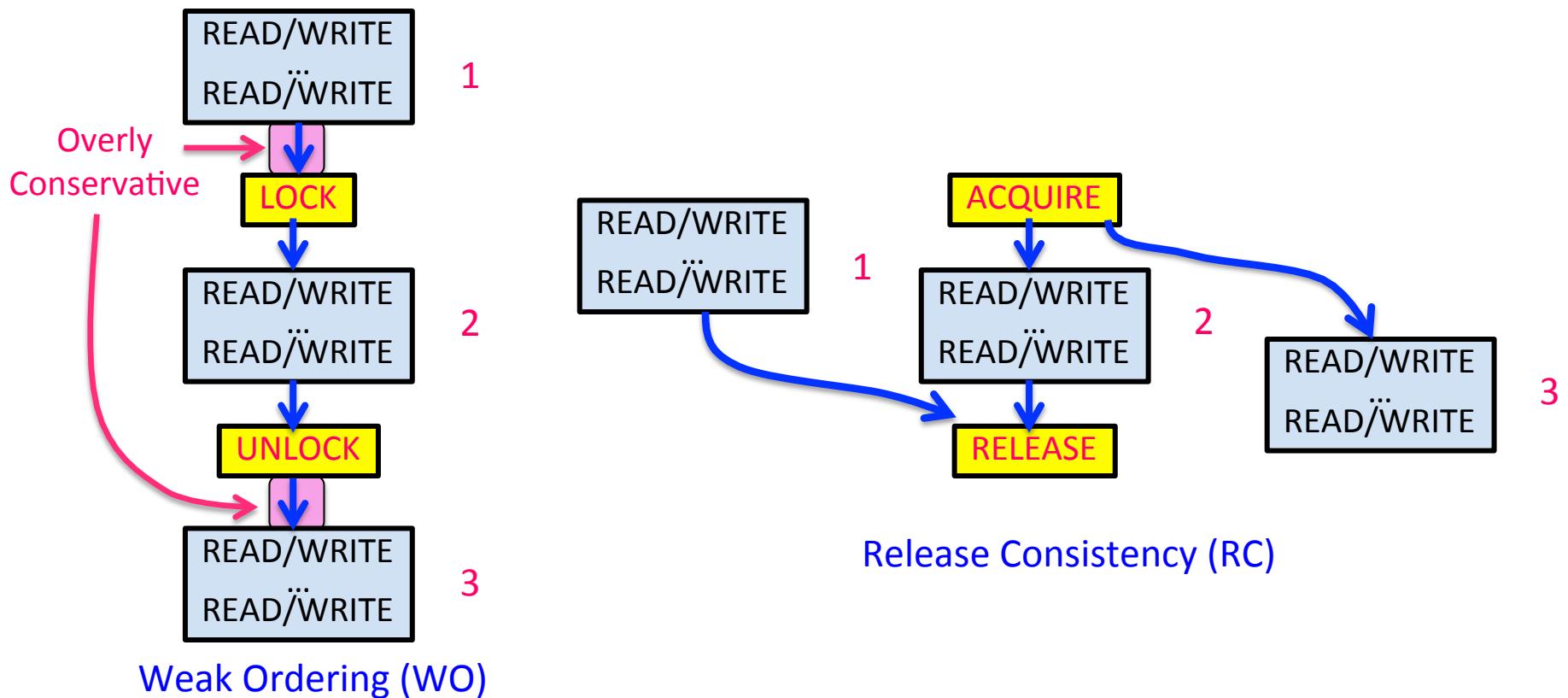

Intel's Full Set of Fence Operations

- In addition to **MFENCE**, Intel also supports two other fence operations:
 - **LFENCE**: serializes only with respect to **load** operations (not stores!)
 - **SFENCE**: serializes only with respect to **store** operations (not loads!)
 - Note: It does slightly more than this; see the spec for details:
 - *Section 8.2.5 of “Intel® 64 and IA-32 Architectures Software Developer’s Manual, Volume 3A: System Programming Guide, Part 1*
- In practice, **you are most likely to use**:
 - **MFENCE**
 - **xchg**

Take-Away Messages on Memory Consistency Models

- **DON'T** use only normal memory operations for synchronization
 - e.g., Peterson's solution (from Synchronization #1 lecture)

```
boolean want[2] = {false, false};  
int turn = 0;
```

```
want[i] = true;  
turn = j;  
while (want[j] && turn == j)  
    continue;  
... critical section ...  
want[i] = false;
```

Exercise for the reader:
Where should we add
fences (and which type)
to fix this?

- **DO** use either explicit synchronization operations (e.g., `xchg`) or fences

```
while (!xchg(&lock_available, 0)  
    continue;  
... critical section ...  
xchg(&lock_available, 1);
```

Summary: Relaxed Consistency

- Motivation:
 - obtain **higher performance** by allowing reordering of memory operations
 - (reordering is not allowed by sequential consistency)
- One cost is **software complexity**:
 - the programmer or compiler must **insert synchronization**
 - to ensure certain specific orderings when needed
- In practice:
 - complexities often encapsulated in libraries that provide intuitive primitives
 - e.g., lock/unlock, barriers (or lower-level primitives like fence)
- Relaxed models differ in which memory ordering constraints they ignore